

Diaphragm Valves

■ DV54 SERIES DIAPHRAGM VALVES



Manual
(Low Pressure)



Manual
(High Pressure)

■ Surface Finish

- Standard Ra: 10-15 μ m

■ Internal Volume

- 1.6 cc

■ Features

- Suitable for high purity applications
- 316L stainless steel enhances weldability and resistance to corrosion
- Both manual and pneumatic actuation are available
- Face seal fittings (FSR) or butt welded connections
- Internal spring-less design
- Metal-to-metal seal minimizes particle generation and ensures high purity in the flow passages
- Handle includes a status window to indicate open / closed position
- Long service life
- 100% Helium leak tested

■ Materials

- Body: 316L
- Seat: PCTFE*, Vespel®**
- Diaphragm: Elgiloy®

■ Specifications

- Cv: 0.3
- Leak Rate
 - Inboard: 1×10^{-9} atm cc/sec He
 - Across Seat: 4×10^{-9} atm cc/sec He
- Proof Pressure: 150% of maximum operating pressure
- Burst Pressure: 400% of maximum operating pressure

■ Operating Conditions

- Maximum operating pressure: 300 psi (20 bar),
3500 psi (240 bar)
- Minimum operating pressure: Vacuum
- Operating temperature: 40°F ~ 150°F (-40°C ~ 65°C)

■ Pneumatic Actuator

- Operating pressure: 70-125 psi
- Inlet Connection: 1/8" NPT(F)
- Working Status: Normally closed

* Standard Material

** Vespel® seat is recommended for Nitrous Oxide (N₂O) service but is not available for low pressure pneumatic actuation

DV54 SERIES DIAPHRAGM VALVES

Dimensions

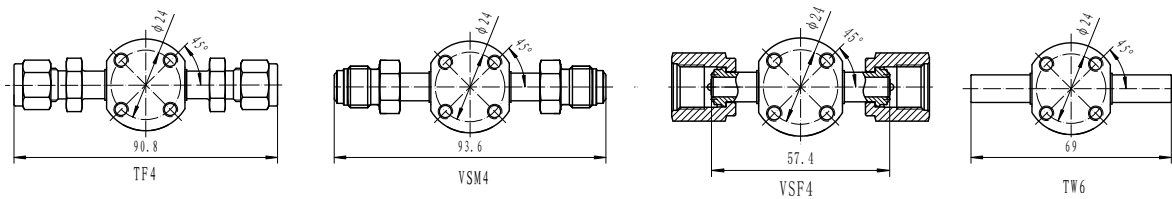
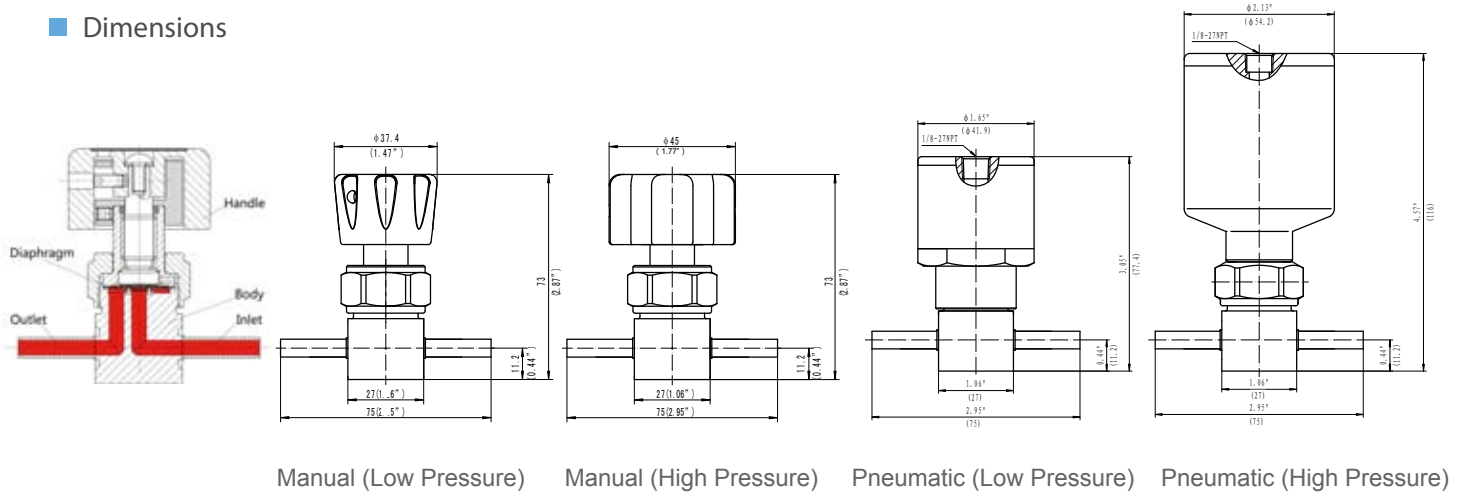

Flow Path Designator

Type	Bypass	Three-way			Four-way		Rear-entry	
Flow schematic	P	B	C	D	I	J	A	T
Red arrow indicates inlet, Blue arrow indicates outlet*								
Flow schematic	Q	E	F	H	K	L	R	
Red arrow indicates inlet, Blue arrow indicates outlet*								

*All schematics are from top view

Ordering Information

SL	-	DV54	M	H	B	-	FNT4	-	NO
Body Material: SL: 136L		Model: DV54	Actuation: M: Manual P: Pneumatic Actuator (Normally closed)	Working Pressure: H: 3500 psi L: 300 psi	Flow Path: Blank: In-line Type Elbow Type P: East in / North out Q: East in / South out Three-way valve B: Right inlet, left / top outlet C: Right inlet, left / bottom outlet D: Right / top inlet, left outlet E: Right inlet, top / bottom outlet F: Top / bottom inlet, left outlet H: Left / right inlet, top outlet Please refer to Flow Path Designator table above		Inlet / Outlet*: TW4 TW6 VSM4 VSF4 TF4		Options: Blank: Standard NO: Normally open (Pneumatic, Low Pressure)

*: For standard models, if the high pressure (inlet) connections and low pressure (outlet) connections are same, list only one..
If different, the prior represents inlet connection, and the latter represents outlet connection.